

# T 158-8P6R33.451 6x6.2

# FORESTRY

## 6x6 LOG-TRUCK WITH TRAILER

Combining outstanding features of the TATRA PHOENIX 6x6 vehicles with an engageable front axle drive, superstructure, UMIKOV stanchion trailer and powerful EPSILON hydraulic crane results in a highly efficient vehicle set for removal and transport of short timber.

TATRA PHOENIX combines the unique TATRA chassis with a spacious and comfortable cab, modern PACCAR MX engines and ZF transmissions. Thanks to this, the TATRA PHOENIX trucks can take you further - to the locations inaccessible to other trucks, and to higher profit due to efficient operation.

The UMIKOV NKD 15 superstructure features crossbars with stanchions with mechanical adjustment according to the transported assortment of wood. The three-axle UMIKOV PN 03/24 trailer with a mechanically adjustable sliding stanchions is made of high-quality materials of S700MC grade, and fitted with BPW or SAF axles with the air suspension with optional lifting of the central axle. The trailer is equipped with a system that provides information about the current axle load. It is a highly effective unit. The vehicle uses hydraulic loading crane Epsilon M 120 Z 96, which allows handling with timber of any length with minimal space requirements. The boom length up to 9.6 meters with the end capacity of 1,210 kg makes the equipment powerful and versatile. Thanks to these parameters, the loading and unloading time can be shortened by up to 60% compared to other models, which brings improved economy of work and operational cost savings.

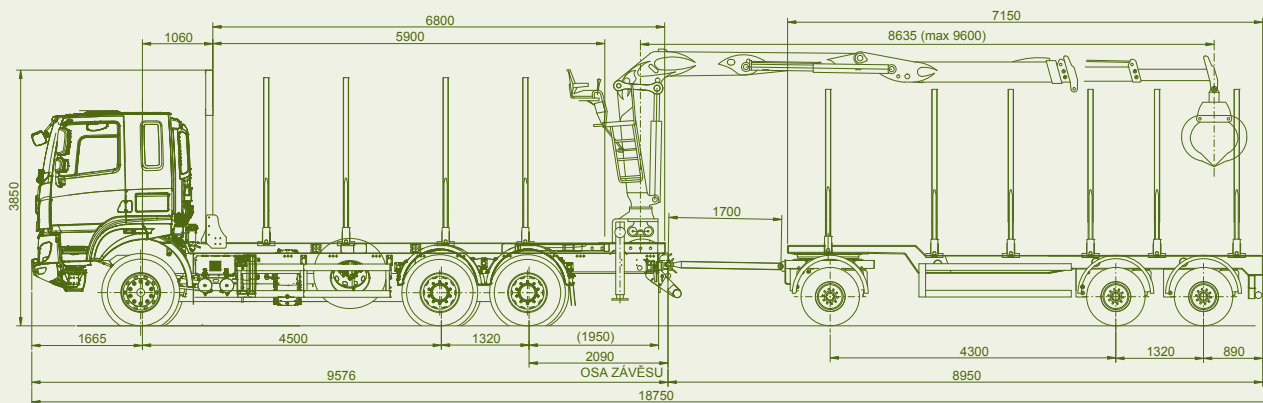

- HIGH PRODUCTIVITY
- EFFICIENT BOTH OFF-ROAD AND ON-ROAD
- TECHNICAL EXCELLENCE OF SUPERSTRUCTURE AND TRAILER
- HIGH-PERFORMANCE LOADER
- COMFORT FOR DRIVERS

TATRA TAKES YOU FURTHER

[tatra-trucks.com](http://tatra-trucks.com)

# TATRA PHOENIX Euro 6



# T 158-8P6R33.451 6x6.2

## 6x6 LOG-TRUCK WITH TRAILER

TATRA  
PHOENIX  
EURO6

### ENGINE

Type PACCAR MX-13 Euro 6  
No. of cylinders 6  
Swept volume 12,900 cm<sup>3</sup>  
Net power 340 kW/1,700 rpm  
Net torque 2,300 Nm/1,000-1,450 rpm  
SCR, EGR, DPF exhaust gas treatment system  
Optional: - MX-13 engine, swept volume 12,900 cm<sup>3</sup>, power 300; 375 kW/1,450 rpm

### TRANSMISSION

Manual ZF- type 16S 2530 TO with integrated retarder-intarder  
Number of speeds 16  
- forward 16  
- reverse 2  
Hydraulically operated clutch, diam. 1x430 mm.  
Optional: automated 16-speed ZF 16AS 2630 AS Tronic, or automatic Allison 4500

### TRANSFER CASE

Two-speed TATRA 2.30 TRK, ratio 0.95/1.44.  
Optional: one-speed (gear ratios 1.12; 1.28; 1.46)

### FRONT AXLE

Steered, driven with swinging half-axes, switchable, drive, axle differential.  
Air-bellows suspension with telescopic shock absorbers.  
Optional: torsion stabilizer

### REAR AXLES

Driven, with swinging half-axes, axle differential locks, inter-axle differential lock.  
Air suspension with bellows, combined with coil springs, telescopic shock absorbers and torsion stabilizer at the last axle (optional).

### STEERING

Left-hand sided, monoblock.

### BRAKES

Four independent brake systems: service, emergency, parking, relief. MX Engine Brake

### TYRES, DISCS

	front	rear
Tyres	385/65 R22.5	315/80 R22.5
Discs	22,5x11,5	9,00x22,5

### CAB

Over-engine, sleeper, hydraulically tilting, with engine-dependent water heating, optionally with A/C or an independent heater,  
Number of seats 2

### FUEL TANK

steel, 300 liters + 45-liter AdBlue

### DIMENSIONS

Width	2,550 mm
Wheelbase	
- front	1,942 mm
- rear	1,774 mm
Ground Clearance	280 mm

### WEIGHTS

Gross vehicle weight	30,000 kg
Gross combination weight	54,000 kg

### ELECTRIC EQUIPMENT

Power grid voltage	24 V
Batteries	2x12V 180 Ah
Alternator	24 V / 80 A

### FEATURES

Climbing capacity at 30,000 kg	70 %
Max. speed (with speed limiter)	85 km/h
Turning diameter (track)	19,0±1.0 m
Fording ability	800 mm

### TRAILER - UMIKOV

Type	PN 3.24
A three-axle trailer without floor with stanchions intended for the transport of wood in lengths of 2-8 m. Three BPW or SAF axles, one of which is liftable. Tyre design - dual tyres or single tyres as per customer's choice. Air suspension. EBS anti-lock braking system.	
Trailer curb weight from	5,000 kg
Maximum gross trailer weight	24,000 kg
Maximum technically allowable trailer weight	27,000 kg

### HYDRAULIC CRANE - EPSILON

Type	M120 Z96
Net lifting torque	119 kNm
Total boom reach	9,600 mm
Pump	PARKER F 2 - 53/53 R
Grapple type	EPSILON FG 53
Weight of crane including props	2,280 kg
Capacity at the end	3,950 kg / 3 m 2,960 kg / 4 m 2,360 kg / 5 m 1,950 kg / 6 m 1,650 kg / 7 m 1,430 kg / 8 m 1,210 kg / 9 m

tatra-trucks.com



Rclt1, U48 Baniyas, Al Wathba, P.O Box 4838,  
Abu Dhabi, United Arab Emirates

+971 2 203 4912

sales@resource-industries.com