

T 158-8P5R33.341 6×6.2

COMMERCIAL



6×6 THREE-WAY TIPPER

The TATRA PHOENIX is a combination of a unique TATRA chassis with a spacious and comfortable cab, modern PACCAR MX engines, and ZF transmissions. Thanks to these features, TATRA TAKES YOU FARTHER - to places which other trucks cannot reach, and also to higher profits thanks to great efficiency and productivity.

The excellent productivity of the TATRA PHOENIX is a result of high payload and high speed that you can achieve in off-road conditions. With TATRA trucks you can transport more material faster.

Efficient PACCAR MX engines offer reasonable operating costs even on hard terrain. The TATRA PHOENIX achieves higher speed and lower fuel consumption compared to competitors' rigid or articulated dump trucks used e.g. in mining operations. In addition, the TATRA unique chassis design together with air suspension on all axles enhances comfort of the TATRA PHOENIX. For GVW over 40 tons (6×6) and 50 tons (8×8), wheel-hub reduction gears are used.

With TATRA PHOENIX 6×6, equipped with automated transmission ZF AS Tronic that is available for all TATRA PHOENIX models, is possible to fully use the automatic gear shifting mode or choose the manual mode, which can bring certain advantages, especially when driving in difficult terrain. AS Tronic offers additional comfort for the driver, optimize fuel consumption and protect driveline against drivers' faults. The automated transmission is complemented with a very practical „hill holder“ feature, ensuring smooth drive-away in a hilly terrain.

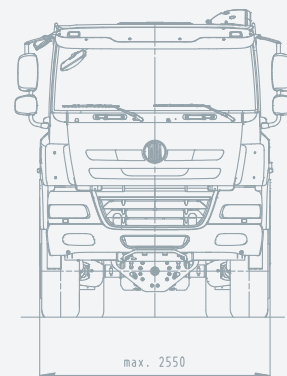
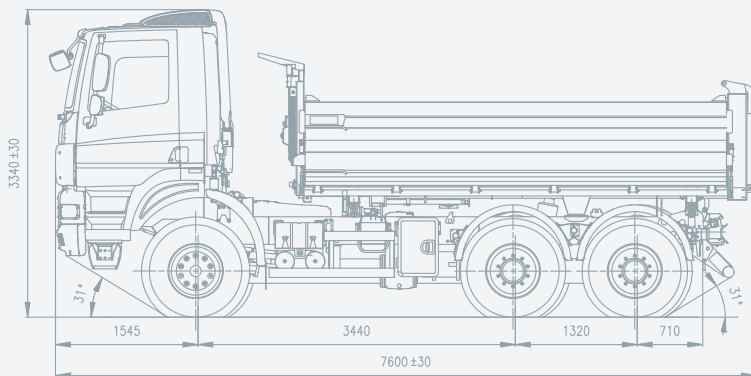

EXCELLENT OFF-ROAD CAPABILITIES

HIGH TRANSPORTATION SPEED

HIGH PAYLOAD

LOW FUEL CONSUMPTION

COMFORT FOR DRIVER

TATRA TAKES YOU FURTHER

tatra-trucks.com

TATRA PHOENIX



T 158-8P5R33.341 6x6.2

6x6 THREE-WAY TIPPER

ENGINE

Type	PACCAR MX300 EURO V
Nos. of cylinders	6
Bore/stroke	130/162 mm
Swept volume	12,900 cm ³
Power (netto)	300 kW/ 1,500 min ⁻¹
Torque (netto)	2,000 Nm/ 1,000 - 1,410 min ⁻¹
Exhausted gas adjustment	SCR

TRANSMISSION

Automated, type ZF 16S AS Tronic.		
nos. of forward	- gears	16
	- reverse	2
Option: transmission retarder (intarder)		

TRANSFER CASE

Type TATRA 1.30 TR 1,28 downward, one-speed.

FRONT AXLE

Steered, driven with swinging half-axles, disengageable front drive, axle differential lock.

Air bellows and telescopic shock absorbers.

REAR AXLES

Driven, with swinging half-axles, axle differential locks, interaxle differential lock.

Air bellows with coil springs and telescopic shock absorbers.

STEERING

Left Hand Drive, Integral power steering.

BRAKES

Wedge type self-adjustable drum brake units, EBS
Four separate brake systems: service, emergency, parking and engine brake.

TYRES, DISCS

Tyres	315/80 R22.5
Discs	9.00x22.5

CABIN

Cab over engine, short, tilting, dependent water heater.
Two seats.

FUEL TANK

Steel, 300l + 45 litres ADBLue.

DIMENSIONS

Width	2,550 mm
Track - front	1,942 mm
- rear	1,774 mm
Clearance	280 mm

WEIGHTS

Curb weight (without tipper)	10,250 kg
Front axle load	5,900 kg
Rear axles load	2x2,175 kg
Payload	19,750 kg
GVW	30,000 kg
Front axle max. permissible load	9,000 kg
Rear axles max. permissible load	2x11,500 kg

ELECTRIC EQUIPMENT

Circuit voltage	24 V
Battery	2x12V 180 Ah
Alternator	24 V/80 A

FEATURES

Climbing capacity at 30,000 kg	100%
Top speed with a limiter	85 km/h
Wall-to-wall turning diameter	17.5±1.0 m

TATRA PHOENIX

tatra-trucks.com



 Rct1, U48 Baniyas, Al Wathba, P.O Box 4838,
Abu Dhabi, United Arab Emirates

 +971 2 203 4912

 sales@resource-industries.com