

T158 - 8P5R36.341 6x6.2R

MINING



6x6 ONE-WAY TIPPER

The TATRA PHOENIX is a combination of a unique TATRA chassis with a spacious and comfortable cab, modern PACCAR MX engines, and ZF transmissions. Thanks to these features, TATRA TAKES YOU FARTHER - to places which other trucks cannot reach, and also to higher profits thanks to great efficiency and productivity.

The excellent productivity of the TATRA PHOENIX is a result of high payload and high speed that you can achieve in off-road conditions. With a TATRA truck you can transport more material faster.

Efficient PACCAR MX engines offer reasonable operating costs even on hard terrain. The TATRA PHOENIX achieves higher speed and lower fuel consumption compared to competitors' rigid or articulated dump trucks used in mining operations. In addition, the TATRA unique chassis design together with air suspension on all axles enhances comfort of the TATRA PHOENIX. For GVW of 40 tons (6x6) and 50 tons (8x8), hub reduction gears are used.

The TATRA PHOENIX is an all-wheel drive truck; front drive is equipped with shift-on-the-fly capability without a need to stop. A possibility to operate also as a non-all-wheel drive truck results in additional fuel saving. The TATRA PHOENIX can also be equipped with a central tire inflation system (CTIS) saving fuel, reducing tire wear, and even improving off-road capabilities.

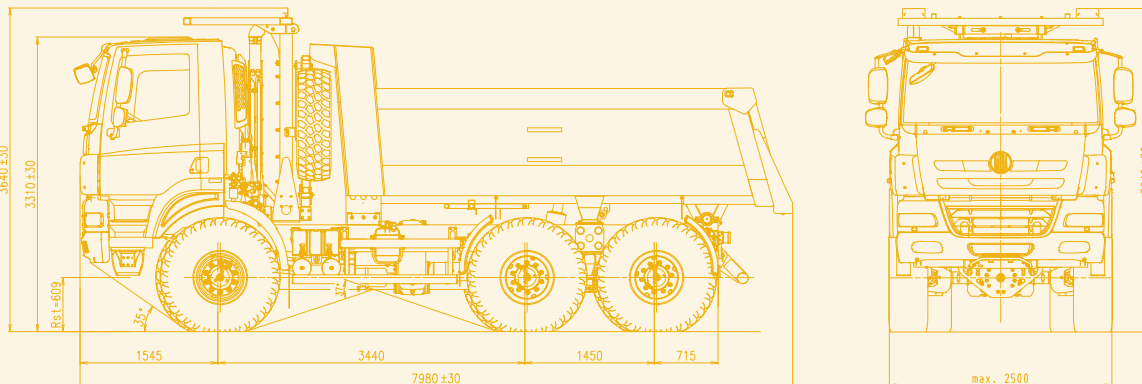

EXCELLENT OFF-ROAD CAPABILITIES

HIGH TRANSPORTATION SPEED

HIGH PAYLOAD

LOW FUEL CONSUMPTION

COMFORT FOR THE DRIVER

TATRA TAKES YOU FURTHER

tatra-trucks.com

TATRA PHOENIX



T158 - 8P5R36.341 6x6.2R

6x6 ONE-WAY TIPPER

ENGINE

Type	PACCAR MX 300
Nos. of cylinders	6
Bore/stroke	130/162 mm
Swept volume	12,900 cm ³
Power	300 kW/1,500 min ⁻¹
Torque	2,000 Nm/1,000 - 1,400 min ⁻¹
Emission level	EURO V (SCR)
MX Engine Brake as an option	
Option: MX 340 engine	

CLUTCH

Type SACHS MFZ 1x430, single disc clutch

TRANSMISSION

Manual	
Type	ZF 16S 2530 TO
Nos. of gears - forward	16
- reverse	2
Option: automated, with electronically controlled clutch, transmission retarder (intarder)	
Type	ZF 16AS 2630 TO
Nos. of gears - forward	16
- reverse	2
Option: transmission retarder (intarder)	

TRANSFER CASE

One-speed	
Type	TATRA 1.30 TR
Option: two-speed version, with shifting at standstill	
Type	TATRA 2.30 TRK

PTOs

Type NH/1C from transmission

FRONT AXLE

Steered, driven with swinging half-axles, axle differential lock. Hub reduction gears. Disengageable front drive. Air bellows and telescopic shock absorbers, torsion bar.

REAR AXLES

Driven, with swinging half-axles, axles and interaxle differential lock. "Heavy combined TATRA suspension" - air bellows with leaf springs.

STEERING

Left Hand Drive
Integral power steering, ZF

BRAKES

Wedge type self-adjustable drum brake units, EBS
Four separate brake systems: service, emergency, parking and engine brake

TIRES, DISCS

	Front	Rear
Tires	16.00 R20*	24.00 R21*
	16.00 R20*	16.00 R20*
	14.00 R20	12.00 R24
	12.00 R24	12.00 R24

Option: central tire inflation system (CTIS)

CABIN

Short, cab over engine, two seats
Option: air conditioning and independent heating

FUEL TANK

Steel, 300 l + 45 liters AD Blue

DIMENSIONS

Wheelbase	3,440 + 1,450 mm
Width	2,500 mm
Track - front	1,942 mm
- rear	1,774 mm
Length	7,575 mm
Height	3,195 mm
Tipper body capacity	14 m ³

WEIGHTS

Curb weight (with tipper body)	16,000 kg
Payload	25,000 kg
GVW	41,000 kg
Front axle max. permissible load	9,000 kg
Rear axle max. permissible load	2x16,000 kg

ELECTRIC EQUIPMENT

Nominal voltage	24 V
Battery	2x12 V 180 Ah
Alternator	24 V/110 A
FMS connector preparation	

VEHICLE PERFORMANCE

Top speed with a limiter	60 km/h
Turning circle diameter (curb to curb)	19,5±1,0 m

COLD WEATHER PACKAGE

Coldstart device up to minus 40°C. Pre-heated fuel filter with water separator. Heated body.

SAFETY OPTIONS

ROPS/FOPS behind the cab

1545

3440

1450

tatra-trucks.com

 Rclt1, U48 Baniyas, Al Wathba, P.O Box 4838,
Abu Dhabi, United Arab Emirates

 +971 2 203 4912

 sales@resource-industries.com

